

# Customer Information Sheet

DRAWING No.: Z2072Z00 & Z2072ZL0

IF IN DOUBT - ASK

©

NOT TO SCALE

THIRD ANGLE PROJECTION

ALL DIMENSIONS IN mm

Z10002-00  
TOP TOOL

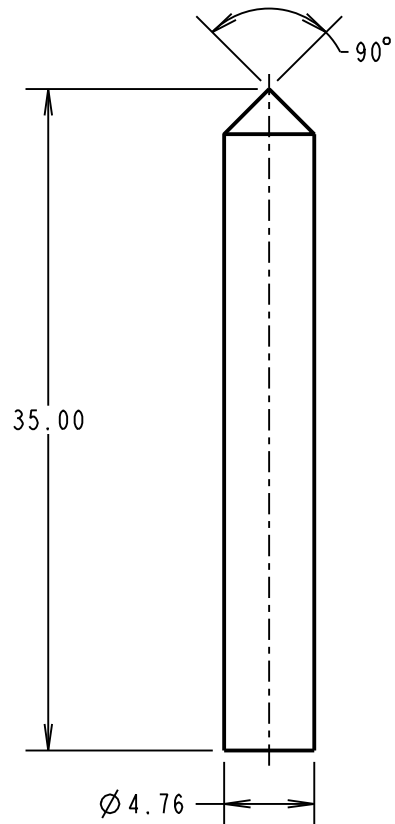

Z10000-00  
BOTTOM TOOL PART  
MACHINED BLANK

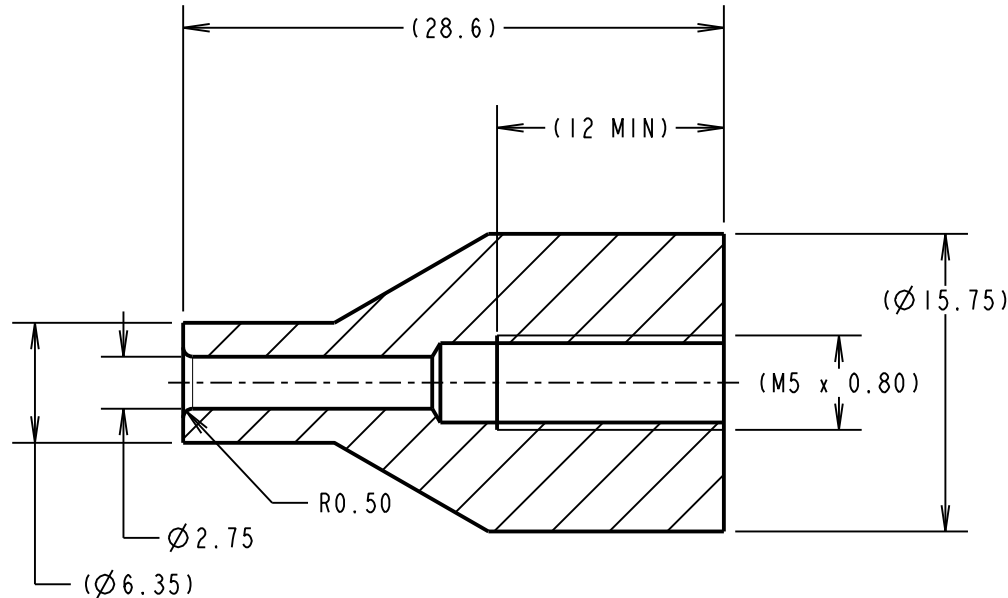

Z10002-00  
(TOP TOOL)

H2072Z01 AND  
H2072ZL1

PCB

Z10000-00  
(BOTTOM TOOL)

OPERATION DIAGRAM

SB	2	19.04.11	11240
NAME	ISS.	DATE	C/NOTE
APPROVED:		S.BENNETT	
CHECKED:		S.FLOWER	
DRAWN:		R.ADDE	
CUSTOMER REF.:			
ASSEMBLY DRG:			

NOTES:

- MUST BE USED WITH A BENCH PRESS OR OTHER FIXED TOOLING, TO ENSURE EVEN PRESSURE IS APPLIED TO THE HEAD OF THE TERMINAL.
- TOP AND BOTTOM TOOLS ARE PACKED IN A BAG AS A KIT.

**HARWIN**

HARWIN USA TEL: 603 893 5376 FAX: 603 893 5396 mis@harwin.com	HARWIN Europe (UK) TEL: 023 9231 4545 FAX: 023 9231 4590 mis@harwin.co.uk	HARWIN Asia TEL: +65 6 779 4909 FAX: +65 6 779 3868 mis@harwin.com.sg
--	--	--

THIS DRAWING AND ANY INFORMATION OR DESCRIPTIVE MATTER SET OUT HEREON ARE CONFIDENTIAL AND COPYRIGHT PROPERTY OF THE HARWIN GROUP AND MUST NOT BE DISCLOSED, LOANED, COPIED OR USED FOR MANUFACTURING, TENDERING OR FOR ANY OTHER PURPOSE WITHOUT THEIR WRITTEN PERMISSION.

TOLERANCES

X. = ±1mm  
X.X = ±0.25mm  
X.XX = ±0.10mm  
X.XXX = ±0.01mm

ANGLES = ±5°  
UNLESS STATED

MATERIAL:

SILVER STEEL

FINISH: CLEAN

S/AREA: mm<sup>2</sup>

TITLE:

TOP AND BOTTOM TOOL SET

DRAWING NUMBER:

Z2072Z00 & Z2072ZL0

SHT

2 OF 2