

PART NUMBER	REV	FIRST USED
680742-3	B	356462-1

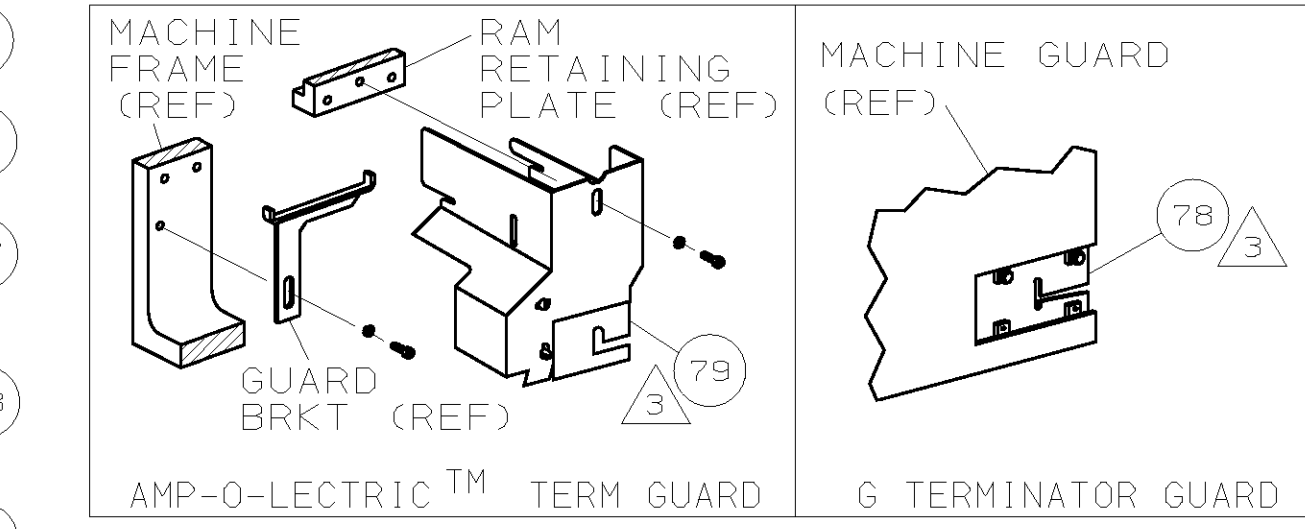
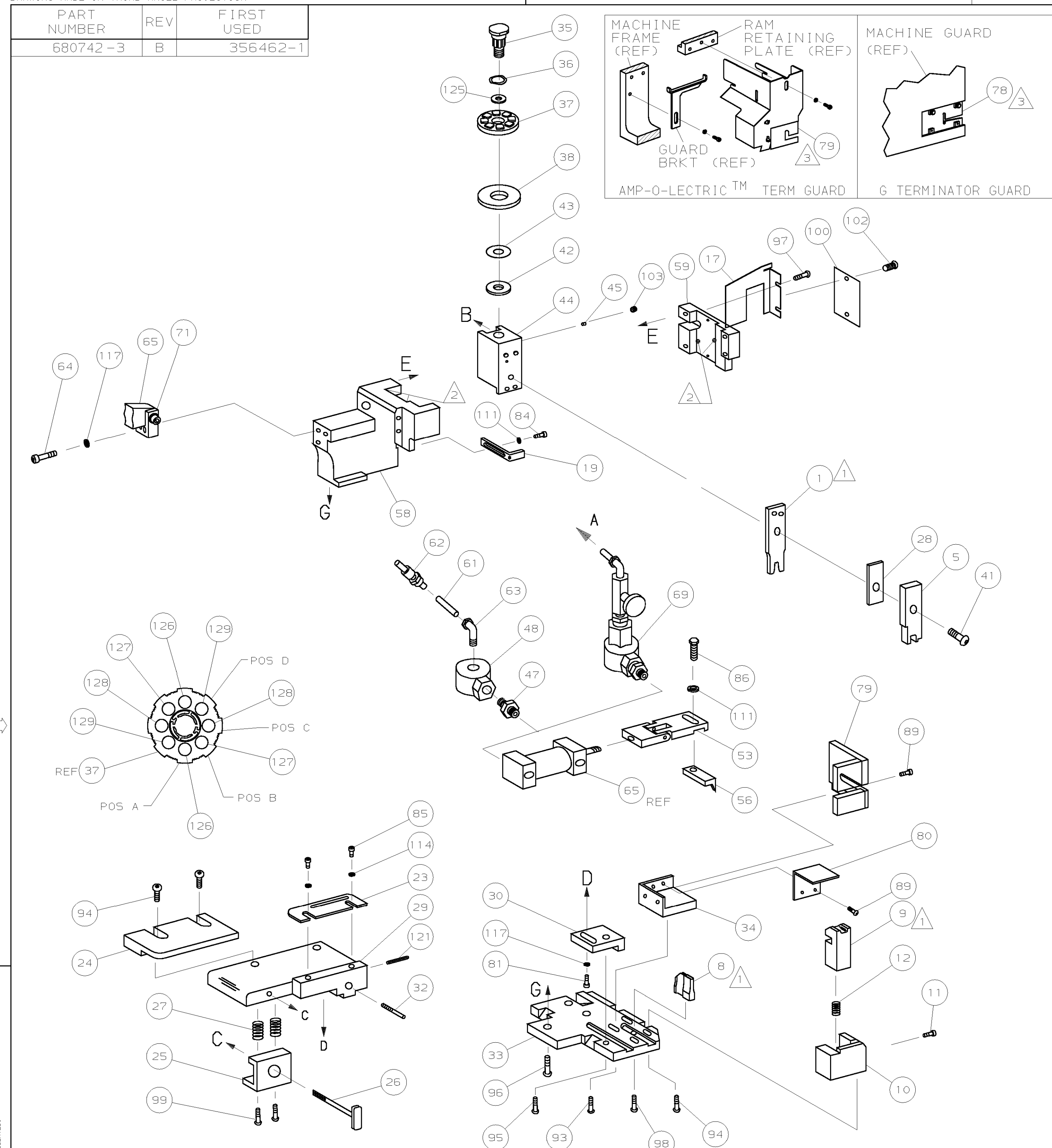

TERMINAL NAME: SPLICE		60372		CRIMPING DATA	
PAD LTR		CRIMP HEIGHT		WIRE SIZE	
A		.073±.002 [1.85 ±0.05mm]		2000 CMA	△6
B		-		-	
C		-		-	
D		-		-	
CRIMP	SIZE	TYPE	RANGE		
WIRE	.090 [2.29mm]	F	1200-2600 CMA		
INSUL	-	-	-		
WIRE STRIP LENGTH	TERM APPL SPEC	FEED	APPL INSTRUCTION	SET UP GAGE	LAYOUT
-	114-02088	.350	408-8040	458637-1	L1314

QTY	REV	DESCRIPTION	ITEM NO
			129
			128
			127
2	-	8-354778-8 PIN, WIRE DISC (.2935)A	126
1	-	986950-1 WASHER, FLAT PRECISION	125
1	-	217238-1 GENERAL INSTRUCTION PACKAGE	124
1	-	4088040 SF APPL INST 408-8040	123
			122
1	-	4-21028-0 PIN, SLT SPR (ø.093x.75) ST GDE PL	121
			120
			119
			118
3	-	21024-5 WASHER, LOCK (#10) ADJ BLOCK	117
			116
			115
2	-	21024-2 WASHER, LOCK (#4) FRONT STP GUIDE	114
			113
			112
2	-	21024-4 WASHER, LOCK (#8) STRIPPER	111
			110
			109
			108
			107
			106
			105
			104
1	-	21009-2 SCR, 5KT SET (1/4-20x.25 LW) RAM	103
2	-	21017-2 SCR, DRIVE (#2x.19) ID PLATE	102
			101
1	-	461264-1 PLATE, IDENTIFICATION	100
2	-	3-21002-0 SCR, BHC (10-32x.88) DRAG	99
1	-	22733-8 SCR, BHC (8-32x.38 LW) ANVIL	98
4	-	2-21002-9 SCR, BHC (10-32x.75) CAP	97
3	-	2-22733-8 SCR, BHC (1/4-20x.62) H5G	96
1	-	2-21002-7 SCR, BHC (10-32x.50) 5G ADJ BLK	95
4	-	2-21002-2 SCR, BHC (8-32x.50) TERM H DWN	94
2	-	2-21002-1 SCR, BHC (8-32x.38) HOLDER	93
			92
			91
			90
4	-	1-21002-3 SCR, BHC (4-40x.19) GUARD	89
			88
			87
1	-	2-22603-1 SCR, HEX HD (8-32x.38) FEED FINGER	86
2	-	1-21000-3 SCR, SHC (4-40x.25) F ST GUIDE	85
1	-	2-21000-7 SCR, SHC (8-32x.50) STRIPPER	84
			83
			82
1	-	3-21000-4 SCR, SHC (10-32x.38) 5G ADJ BL	81
1	-	662196-1 SHIELD	80
1	-	662197-1 GUARD, TERMINAL	79
REF	-	356467-1 GUARD	78
			77
			76
			75
			74
			73
			72
1	-	459610-3 MOUNT, FEED BRACKET	71

- △1 RECOMMENDED SPARE PARTS.
- △2 GREASE LIGHTLY.
- △3 GUARD MUST BE IN PLACE WHEN OPERATING APPLICATOR IN A BENCH MACHINE.
- △4 SEE DRAWING FOR COMPONENTS
- △5 CUT TO LENGTH AT ASSY.
- △6 USE FOR SET UP ONLY.

QTY	REV	DESCRIPTION	ITEM NO
			70
			69
			68
			67
			66
1	-	461065-1 AIR FEED ASSY (1 INCH)	65
2	-	3-21000-9 SCR, SHC (10-32x1.00) AIR ASSY	64
1	-	980285-2 ELBOW, SWIVEL 1/8 NPT - 1/4 T	63
1	-	23238-1 QUICK DISCONNECT	62
21.00	IN	27319-4 TUBING, POLY-FLO ø.25	61
			60
1	-	454220-1 CAP, RAM	59
1	-	454485-1 HOUSING	58
			57
			56
			55
			54
1	-	461062-1 FEED FINGER ASSY	53
			52
			51
			50
			49
1	-	22374-7 VALVE, QUICK EXHAUST	48
1	-	22304-1 NIPPLE, HEX 1/8 NPT	47
			46
1	-	690191-1 PLUG, NYLON	45
1	-	455673-1 RAM	44
1	-	690125-1 WASHER, LAMINATED	43
1	-	690124-1 WASHER, RAM	42
1	-	7-21002-9 BOLT, CRIMPER (5/16x1.00)	41
			40
			39
1	-	690223-2 SPACER, INSULATION DISC	38
1	-	354777-1 WIRE DISC, PLASTIC	37
1	-	22480-5 WASHER, SPRING	36
1	-	690212-1 POST, RAM	35
1	-	662195-1 HOLDER, GUARD	34
1	-	356600-1 PLATE, BASE	33
1	-	690432-3 SCREW, ADJUSTMENT	32
			31
1	-	455689-1 BLOCK, STRIP GUIDE ADJ	30
1	-	455671-1 PLATE, STRIP GUIDE	29
1	-	4-455888-1 SPACER, FRONT SHEAR DEP	28
2	-	1-22284-0 SPRING, DRAG	27
1	-	690546-1 LEVER, DRAG RELEASE	26
1	-	240792-1 DRAG, TERMINAL	25
1	-	690748-8 GUIDE, STRIP (REAR)	24
1	-	690438-1 GUIDE, STRIP (FRONT)	23
			22
			21
			20
1	-	690472-2 STRIPPER	19
			18
1	-	356598-1 GUARD	17
			16
			15
			14
			13
1	-	6-22279-4 SPRING, SHEAR	12
1	-	690461-1 STOP, SHEAR	11
1	-	468798-1 HOLDER, SHEAR (FRONT)	10
1	-	462006-3 SHEAR, FLOAT (FRONT)	9
1	-	4-683403-3 ANVIL	8
			7
			6
1	-	1-455889-3 DEPRESSOR, SHEAR (FRONT)	5
			4
			3
			2
			1
1	-	4-456406-2 CRIMPER, WIRE	1

QTY	REV	DESCRIPTION	ITEM NO
1	-	459610-3 MOUNT, FEED BRACKET	71

QTY	REV	DESCRIPTION	ITEM NO
1	-	4-456406-2 CRIMPER, WIRE	1

THIS DRAWING IS A CONTROLLED DOCUMENT.

THIS DRAWING IS UNCLASSIFIED - RELEASED FOR PUBLICATION - JAN 05, 1999 - BY AMP INCORPORATED. ALL RIGHTS RESERVED.

LOC A  
DIST 66

AMP 1756 REV 3-92 02-AUG-99 13:14:44 amp14442 7

QTY	REV	DESCRIPTION	ITEM NO
1	-	459610-3 MOUNT, FEED BRACKET	71

DIMENSIONS IN INCHES. DO NOT SCALE PRINT. TOLERANCES UNLESS OTHERWISE SPECIFIED:

2 PLC DEC ±  
3 PLC DEC ±  
4 PLC DEC ±  
ANGLES ±  
SURF TEXTURE: ✓  
REMOVE BURRS, BREAK SHARP EDGES R.015 MAX

MATL - HT TR - FIN -

DR W.HOOVER 04NOV98 APP 04NOV98 T.ELBIN  
CHK 04NOV98 REL -  
C.ERISMAN

AMP AMP Incorporated Harrisburg, PA 17105-3608

NAME SIDE FEED HDM APPLICATOR MACHINE REF MINI APPL

SCALE - DWG NO 680742 SHEET 1 OF 1 REV B

CASE CODE 00779 CUSTOMER AND ASSEMBLY DRAWING RESTRICTED TO